

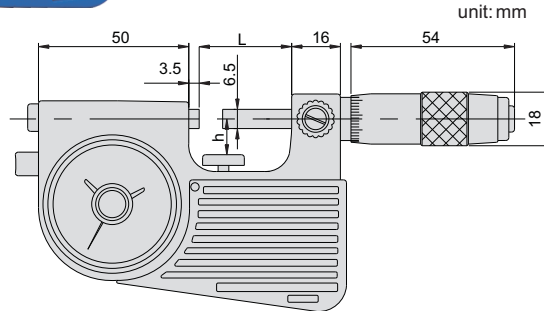

- ◆ Micrometer head graduation: 0.01mm
- ◆ Dial indicator: graduation 0.001mm, accuracy 0.001mm
- ◆ Carbide measuring faces
- ◆ Supplied with setting standards (except 0-25mm)

349-001-01



Setting standards(included)



Code	Micrometer head range	Accuracy	Indicator range	L	h	Setting standards (included)
349-001-01	0-25mm	±3μm	60μm	28.5	19	-
349-002-01	25-50mm	±3μm	60μm	53.5	30	25mm
349-003-01	50-75mm	±4μm	60μm	78.5	45	50mm
349-004-01	75-100mm	±4μm	60μm	103.5	57	75mm