

- ◆ Holder vertical travel: 150mm
- ◆ Fine adjustment range: 2mm

Application

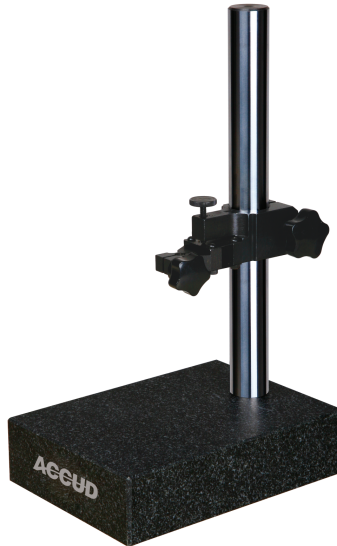

289-008-01

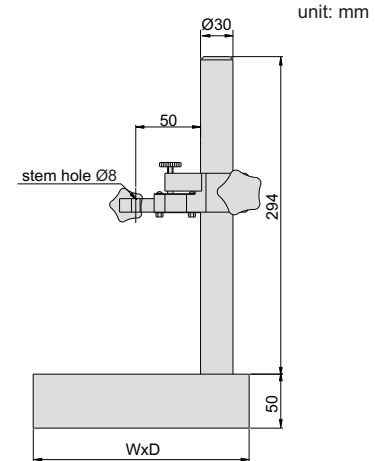

Code	Stem hole	Base flatness	Base size (WxD)
289-008-01	Ø8mm	3.2µm	200x150mm
289-012-01	Ø8mm	3.2µm	300x200mm