

- ◆ Grooved bottom for cylinder
- ◆ Two pins to be set against the edge of surface plate

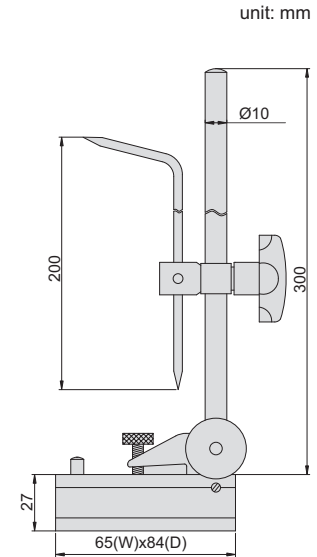
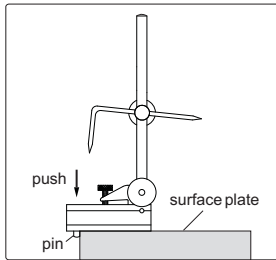
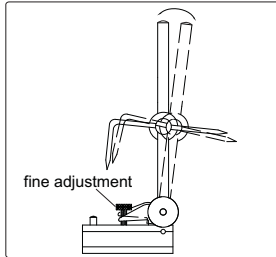

Code

903-012-11